

CERTIFIKÁT EÚ SKÚŠKY TYPU

EU – type examination certificate

Číslo dokumentu: **SK 20-MI001-SMU062** **Revízia 2**
Document number: *Revízia 2 nahrádza certifikát zo dňa 9. Septembra 2020* *Revision 2*
Revision 2 replaces the certificate issued by September 9, 2020

V súlade s: prílohou č. 2, Modul B nariadenia vlády Slovenskej republiky č. 145/2016 Z. z. o sprístupňovaní meradiel na trhu v znení nariadenia vlády SR č. 328/2019 Z. z., ktorým sa preberá smernica Európskeho parlamentu a Rady 2014/32/EU o harmonizácii právnych predpisov členských štátov týkajúcich sa sprístupnenia meradiel na trhu
In accordance with: Annex II, Module B to Government Ordinance of the Slovak Republic No. 145/2016 Coll. Relating to the making available on the market of measuring instruments as amended by Government Ordinance of the Slovak Republic No. 328/2019 Coll., which implemented the Directive 2014/32/EU of the European Parliament and of the Council on the harmonisation of the laws of the Member States relating to the making available on the market of measuring instruments

Žiadateľ/Výrobca: **Arad Dalia Ltd.**
Issued to (Manufacturer): **Kibbutz Dalia 19239, Israel**

Druh meradla: **Vodomer (MI-001)**
Type of instrument: **Water meter (MI-001)**

Označenie typu: **Octave**
Type designation:

Základné požiadavky: príloha č. 1 a príloha č. 3 Vodomery (MI-001) k nariadeniu vlády SR č. 145/2016 Z. z. v znení nariadenia vlády SR č. 328/2019 Z. z.
Essential requirements: Annex No. 1 and Annex No. III Water meters (MI-001) to Government Ordinance of the Slovak Republic No. 145/2016 Coll. as amended by Government Ordinance of the Slovak Republic No. 328/2019 Coll.

Platnosť do: **14. august 2030**
Valid until: **August 14, 2030**

Notifikovaná osoba: **Slovenský metrologický ústav 1781**
Notified body: **Slovak Institute of Metrology 1781**

Dátum vydania: **13. november 2020**
Date of issue: **November 13, 2020**

Základné charakteristiky, popis meradla a podmienky schválenia sú uvedené v prílohe, ktorá je súčasťou tohto certifikátu. Certifikát vrátane prílohy má spolu 16 strán.
Essential characteristics, instrument description and approval conditions are set out in the appendix hereto, which forms the part of the certificate. The certificate including the appendix contains 16 pages.



Viliam Mazúr
zástupca notifikovanej osoby
representative of notified body

Poznámka: Tento certifikát EÚ skúšky typu môže byť rozmnožovaný len celý a nezmenený. Bez podpisu a odtlačku pečiatky je neplatný.
Note: This EU-type examination certificate shall not be reproduced except in full. Certificates without signature and stamp are not valid.

History of the Certificate

Issue of the Certificate	Date	Modification
SK 20-MI001-SMU062, Revision 0	August 14, 2020	Initial certificate
SK 20-MI001-SMU062, Revision 1	September 9, 2020	Plastic body DN40 (add new Q_3 and R)
SK 20-MI001-SMU062, Revision 2	November 13, 2020	Software version update

1 Instructions and standards used within assessment

1.1 Generally binding instructions

Meter type was examined in terms of request for given type provisions Government Ordinance of the Slovak Republic No. 145/2016 Coll. relating to the making available on the market of measuring instruments as amended by Government Ordinance of the Slovak Republic No. 328/2019 Coll., which implemented the Directive 2014/32/EU of the European Parliament and of the Council of 26 February 2014 on the harmonisation of the laws of the Member States relating to the making available on the market of measuring instruments as later amended (next Government Ordinance).

Requirements are set out in Annex No. 1 and Annex No. 3 Water Meters (MI-001) to Government Ordinance of SR No. 145/2016 Coll. as amended by Government Ordinance of the Slovak Republic No. 328/2019 Coll..

1.2 Harmonized standards and normative documents used

OIML R 49-1:2006	Water meters intended for the metering of cold potable water and hot water. Part 1: Metrological and technical requirements
OIML R 49-2:2004	Water meters intended for the metering of cold potable water and hot water. Part 2: Test methods
EN 14154-1:2005+A2:2011	Water meters - Part 1: General requirements
EN 14154-2:2005+A2:2011	Water meters - Part 2: Installation and conditions of use
EN 14154-3:2005+A2:2011	Water meters - Part 3: Test methods and equipment

1.3 Other instructions used:

OIML R 49-1:2013	Water meters intended for the metering of cold potable water and hot water. Part 1: Metrological and technical requirements
OIML R 49-2:2013	Water meters intended for the metering of cold potable water and hot water. Part 2: Test methods
OIML R 49-3:2013	Water meters intended for the metering of cold potable water and hot water. Part 3: Test report format
EN ISO 4064-1: 2017	Water meters for cold potable water and hot water. Part 1: Metrological and technical requirements
EN ISO 4064-2: 2017	Water meters for cold potable water and hot water. Part 2: Test methods
EN ISO 4064-5: 2017	Water meters for cold potable water and hot water. Part 5: Installation requirements

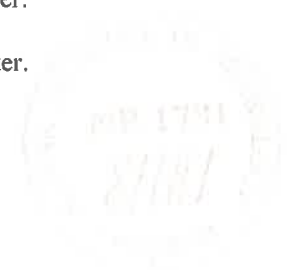

2 Type marking

Ultrasonic water meter – Octave

Meter is made in following subgroups:

Type of meter	Temperature class	Class	Nominal Diameter
Octave Polymer			DN40, DN50
Octave Stainless Steel threaded connections	T50	M1 ¹⁾	DN40, DN50
Octave Stainless Steel Floating Flanges connections		O ²⁾	DN50 – DN200
Octave Iron Flanged connections		E1 ¹⁾	DN50 – DN300

3 Description of measuring instrument

Meter name: Octave is an ultrasonic water meter

Type marking: DN40 – DN300

Description of operating principle instrument design:

This pattern for a family of liquid measuring instruments for measuring the volume of cold water which has passed through them. They are an ultrasonic, flanged water cold-water meter having a Q_3 (permanent flowrate) from 40 m³/h for the 40 mm meter to 1000 m³/h for the 300 mm meter, all sizes with a Q_3/Q_1 turndown ratio of 500 (R500).

The Octave instruments are ultrasonic water meters, which use the Transit time method. This method is based on the physical phenomena where the speed of an ultrasonic wave propagation is equal to the sum of the speed of the flow and the speed of sound of the media at rest. By measuring the time of the wave propagation of both the upstream and downstream the flow, it is possible to obtain the fluid's velocity along the acoustical beam.

The meter does not include mechanical or moving parts, and is mainly consist of hollow tube body with couple of sensors and electronic measuring unit, when the PCB and software are prevented by polyurethane from water damage, according to IP68. The body of water meter could be with regular design or with reinforced design.

Water meters could be installing for mounting on pipelines in every possible position. The water meter designed to measure reverse flow.

All the meters can be pre-equipped for option of having a signal for remote reading purposes - automated computerized system (wireless metering system) for controlling of metering of delivered water quantity, which was not part of this certification.

¹ according to Government Ordinance of the Slovak Republic, Annex No. 1

² according to EN ISO 4064-1:2017 and OIML R 49-2:2013



Picture No.1 Octave Plastic (Polymer) and Stainless-Steel threaded models



Picture No.2 Octave Iron Flanged connection



Picture No.3 Octave S. St. Flanged

Faint circular stamp or watermark in the bottom right corner.

3.1 Description of subgroups

Marking: Octave DN40-DN300

The meter can be equipped by following devices (which was not part of this certification):

- Protective Crown
- Dialog 3G- Meters emitting a RF signal for remote reading purposes which was not part of this certification
- Encoder and Pulse out (SSR) – Wired communication, which transmit volume, alerts and ID.
- W-Mbus/OMS – RF translation of data, according to protocol request
- Pulse Output Module
- 4-20mA Output Module
- AMR Output Module
- Dry Contact

3.2 Measuring insert

The measuring unit group consists of the sealed capsule of measuring electronic unit, and the measuring tube with piezoelectric sensors.





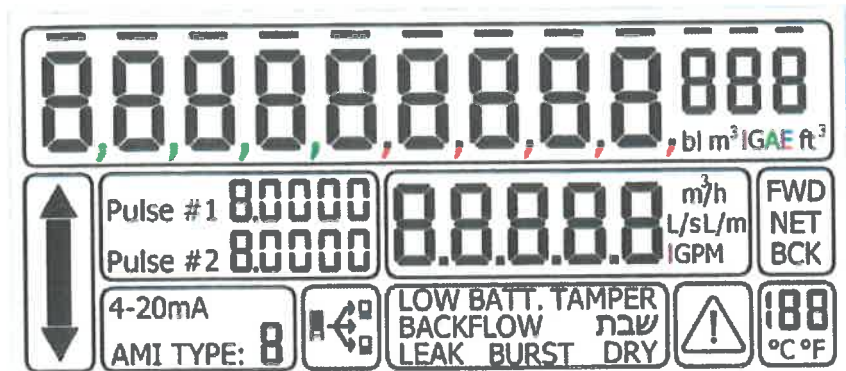

3.3 Indicating device

The capacity of the counter is 999999999,999 m³ for size DN40 up to DN300 and minimum resolution of the reading is 0,01 Litre (In this case the dot replaced with hyphen). The measuring units, as the body as well, made of heavy composite materials and protect damage, contamination and humidity (according to IP68).

Black digits marked on digital drums or black pointers indicate cubic meters or their multiples whereas red digits pointers or small digits indicate submultiples of cubic meters.





1	Volume accumulator include 9 large digits +3 small digits		
2	New Icons	<ol style="list-style-type: none"> 1.  - Display volume 2.  - Detecting icons 3.  - Pulse resolution 4.  - Outputs 	
3	Units	<ol style="list-style-type: none"> 1.  - Volume 2.  - Flow 	

Picture No.4: LCD display with key

3.4 Principle of operation

The potable water enters the meter from the inlet of the meter with initial speed. Sensors have sent ultrasonic pulses during water flow, and pulse velocity depend of water flow speed. Knowing the impulse velocity in stagnant water, a mathematical equation is solved, as a result of which, the flow velocity is established. The velocity, volume and the other information is recurred on LCD display. The water meter is designed to measure the flow rate and amount of supplied cold water and warm water.

3.5 Technical documentation

A number of drawings of technical documentations are listed in the following table:

Drawing No.	Description
13970009/00	Octave 10 DN 250 ISO
13980009/00	OCTAVE DN 300 ISO
32274000/03	Body OCTAVE iron 10 cast
32274009/03	Body OCTAVE iron 10 ISO
32284000/01	Body OCTAVE iron 12 cast
13910055IL/00	OCTAVE DN50-DN300 IRON
13912055IL/00	OCTAVE DN50-DN150 FLOATING FLANGES
13913055IL/00	OCTAVE DN40-DN50 threaded
13910011V4/00	OCTAVE DN 50 ISO R500 V4.02
13930011V4/00	OCTAVE DN 80 ISO R500 V4.02
13940011V4/00	OCTAVE DN 100 ISO R500 V4.02
31535009/02	Body OCTAVE 1.5 plastic threaded
38815109/00	Body OCTAVE 1.5 L=300 threaded s.st
38820309/00	Body OCTAVE 2 L=300 threaded s.st
38821009/00	Body OCTAVE 2 L 200 s.st. w o flanges
13914309V402 / 00	OCTAVE 2" S.ST THREADED R500
1 39 150 09V4 /00	OCTAVE 2" COMPOSITE WITH THREADS
1 39 050 09V4EXPLD/ 00	OCTAVE 1 1/2" COMPOSITE WITH THREADS G2B R250
1 39 050 09V4 /00	OCTAVE 1 1/2" COMPOSITE WITH THREADS G2B R250

All drawings, schemes and technical documentations used during the conformity assessment are saved in document No. NO-455/20, NO-463/20 and NO-473/20.

4 Basic technical characteristics

Type marking		Octave								
Nominal diameter DN	mm	40	50	65	80	100	150	200	250	300
Indicating range	m ³	10 ⁹								
Resolution of the reading	m ³	0,00001								
Maximum admissible pressure	-	MAP16								
Working pressure range	bar	from 0,3 to 10								
Pressure loss	-	Δp 16								
Temperature class	-	T50								
Flow profile sensitivity classes	-	U0, D0								
Position	-	H, V								
Climatic and mechanical environments	-	closed spaces /from -25°C to 55°C/mech. class M1, class O for fixed meters installed outdoor								
Electromagnetic environments	-	E1								
Reverse Flow	-	The meter may or may not measure reverse flow depending on factory set-up. This should be marked on the Data Label								

4.1 Additional technical characteristics

Environmental protection (IP Code)	IP 68		
Weight	Specified the item 10.1 of this Annex		
Power Supply	The electronic card is powered from two batteries size D.		
	• Battery lithium Thionyl Chloride :3.6Vdc		
	• Nominal capacity 19Ah		
	• Rated voltage 3.6V		
	• Maximum recommended continuous current 100 mA		
	• Maximum 1 sec. pulse capability 200 mA		
	• Volume 26 cc		
Data logger	• Operating temperature range -55 °C to +85 °C		
	• U.L. Component Recognition, MH 12193		
Display	Volumes and alarms data (48 kB, 4130 data points)		
Software	LCD, 12 digits accumulation volume		
	Type P, Extension I, Risk Class I (Welmeq Guide 7.2, 2019)		
	Version	Checksum	5 last digits displayed on LCD
Software version and checksum	4.02.09	6059914E	9914E
	4.02.17	60FCCB7	FCCB7
	4.02.95	2FB969A4	969A4
	4.02.97	B098989E	8989E

5 Basic metrological characteristics

The maximum permissible error (accuracy class):

$$\pm 5 \% (Q_1 \leq Q < Q_2)$$

$$\pm 2 \% (Q_2 \leq Q \leq Q_4) \text{ for water temperature (from 0,1 to 30) } ^\circ\text{C}$$

$$\pm 3 \% (Q_2 \leq Q \leq Q_4) \text{ for water temperature greater than 30 } ^\circ\text{C}$$

For Octave iron with R80:

Nominal Diameter	DN	mm	40	50	65	80	100
Minimum flowrate	Q_1	m ³ /h	0,5	0,5	0,5	0,8	1,25
Transitional flowrate	Q_2	m ³ /h	0,8	0,8	0,8	1,3	2,0
Permanent flowrate	Q_3	m ³ /h	40	40	40	63	100
Overload flowrate	Q_4	m ³ /h	50	50	50	80	125
Measuring range R	Q_3/Q_1	-	80				
Ratio	Q_2/Q_1	-	1,6				
Pressure loss	Δp	-	16				

Nominal Diameter	DN	mm	150	200	250	300
Minimum flowrate	Q_1	m ³ /h	3,125	5	12,5	12,5
Transitional flowrate	Q_2	m ³ /h	5,0	8	20	20
Permanent flowrate	Q_3	m ³ /h	250	400	1000	1000
Overload flowrate	Q_4	m ³ /h	313	600	1250	1250
Measuring range R	Q_3/Q_1	-	80			
Ratio	Q_2/Q_1	-	1,6			
Pressure loss	Δp	-	16			

For Octave iron with R500:

Nominal Diameter	DN	mm	40	50	65	80	100
Minimum flowrate	Q_1	m ³ /h	≥ 0,08	≥ 0,08	≥ 0,08	≥ 0,125	≥ 0,20
Transitional flowrate	Q_2	m ³ /h	≥ 0,128	≥ 0,128	≥ 0,128	≥ 0,2	≥ 0,32
Permanent flowrate	Q_3	m ³ /h	40	40	40	63	100
Overload flowrate	Q_4	m ³ /h	50	50	50	80	125
Measuring range R	Q_3/Q_1	-	≤ 500 ³⁾				
Ratio	Q_2/Q_1	-	1,6				
Pressure loss	Δp	-	16				

Nominal Diameter	DN	mm	150	200	250	250	300
Minimum flowrate	Q_1	m ³ /h	≥ 0,5	≥ 0,8	≥ 1,26	≥ 2	≥ 2
Transitional flowrate	Q_2	m ³ /h	≥ 0,8	≥ 1,28	≥ 2,02	≥ 3,2	≥ 3,2
Permanent flowrate	Q_3	m ³ /h	250	400	630	1000	1000
Overload flowrate	Q_4	m ³ /h	313	600	787,5	1250	1250
Measuring range R	Q_3/Q_1	-	≤ 500 ³⁾				
Ratio	Q_2/Q_1	-	1,6				
Pressure loss	Δp	-	16				

5.1 Authorized alternatives

5.1.1 50 mm Threaded body meter

Having a 50mm meter with the same technical specifications as described in section 5, but with a threaded connection replacing the flanges

5.1.2 40 and 50 mm Plastic body with thread connections

As described in the certificate but having a plastic body meter with the following specifications.

³⁾ The ratio Q_3/Q_1 shall be chosen from ISO 4064-1:2017 4.1.4

Nominal Diameter	DN	mm	40	40	40	40	50	50	50
Minimum flowrate	Q_1	m ³ /h	0,08	0,125	0,16	0,08	0,08	0,125	0,08
Transitional flowrate	Q_2	m ³ /h	0,128	0,2	0,256	0,128	0,128	0,2	0,128
Permanent flowrate	Q_3	m ³ /h	16	25	40	40	16	25	40
Overload flowrate	Q_4	m ³ /h	20	31,25	50	50	20	31,25	50
Measuring range R	Q_3/Q_1		200	200	250	500	200	200	500

5.1.3 250 mm Meter iron

Having the flanged design meter as described in section 1 but with 250 mm diameter having either a Q_3/Q_1 turndown ratio of 500 (R500) or 315 (R315), with the following related flowrates.

5.1.4 Stainless Steel Body

As described in the certificate but having a Stainless-Steel meter

DN40-DN50 with threaded connections, DN50-DN150 with flouting flanges connections with the following specifications:

Nominal Diameter	DN	mm	40	50	65	80	100	150
Minimum flowrate	Q_1	m ³ /h	≥ 0,08	≥ 0,08	≥ 0,08	≥ 0,125	≥ 0,20	≥ 0,5
Transitional flowrate	Q_2	m ³ /h	≥ 0,128	≥ 0,128	≥ 0,128	≥ 0,2	≥ 0,32	≥ 0,8
Permanent flowrate	Q_3	m ³ /h	40	40	40	63	100	250
Overload flowrate	Q_4	m ³ /h	50	50	50	80	125	313
Measuring range R	Q_3/Q_1	-	≤ 500 ⁴⁾					
Ratio	Q_2/Q_1	-	1,6					
Pressure loss	Δp	-	16					

5.1.5 40 mm Plastic body with thread connections.

As described in the certificate but having a plastic body meter with the following specifications.

Nominal Diameter	DN	mm	40
Minimum flowrate	Q_1	m ³ /h	0,032
Transitional flowrate	Q_2	m ³ /h	0,0512
Permanent flowrate	Q_3	m ³ /h	16
Overload flowrate	Q_4	m ³ /h	20
Measuring range R	Q_3/Q_1		500

⁴⁾ The ratio Q_3/Q_1 shall be chosen from ISO 4064-1:2017 4.1.4

5.1.6 Octave (PCBA version 3.0)

As described in the certificate but having alternative internal electronics and the following additional functionality (performance not part of this approval):

NFC inductive Communication	Add the ability to communicate (set/get parameters of the meter) through inductive Communication
Shabat mode	New measurement scheme for shabat. Valid only for the Israeli market.
LCD	Add new icons functionality
Data logger + Real time clock	Add ability to save flow and volume records/alarms/histograms
Tamper	Add vandal detection option
ModBus	Add the ability to communicate (set/get parameters of the meter) through ModBus Communication
Pressure Sensor	Add the option to measure water pressure

6 Results of conformity assessment

The results of tests, assessments and evaluations given in the evaluation report No. NO-473/20/B/ER dated November 12, 2020 give sufficient evidence, that the technical design of the measuring instrument – Ultrasonic water meter – type Octave is in compliance with the technical requirements of the Slovak Republic Governmental Ordinance No. 145/2016 Coll. relating to the making available on the market of measuring instruments as amended by Government Ordinance of the Slovak Republic No. 328/2019 Coll., Annex No. 1 and Annex No. 3 Water Meters (MI-001) and the EN 14154-1:2005+A2:2011, EN 14154-2:2005+A2:2011, EN 14154-3:2005+A2:2011 and OIML R49-1:2006, OIML R49-2:2004 (harmonised standards and normative documents) and other instructions EN ISO 4064-1:2017, EN ISO 4064-2:2017 and EN ISO 4064-3:2014 standards, which are relevant for this type of meter.

7 Data placed on the measuring instrument

On the shroud, the dial of the indicating device or on an identification plate of every water meter or in the product documentation minimum the following data should be marked:

- a) Manufacturer's name, registered trade name or registered mark
- b) Postal address of manufacturer at which they can be contacted
- c) Type of the Ultrasonic water meter
- d) Measuring unit (m³)
- e) Numerical value of Q_3 in m³/h (Q_3 x,x) and ratio Q_3/Q_1 (Rxxx)
- f) Year of production
- g) Production serial number
- h) Number of EU-type examination certificate and conformity mark
- i) The highest admissible pressure if it differs from 1 MPa (MAP xx)

- j) Flow direction
- k) The letter V or H, if the meter can only be operated in the vertical or horizontal position
- l) Class of pressure loss if it differs from Δp_{63} (Δp XX)
- m) The installation sensitivity class where it differs from U0/D0 ($U_x D_x$)
- n) The temperature class where it differs from T30
- o) Environmental classification
- p) Electromagnetic environmental class
- q) For a non-replaceable battery: the latest date by which the meter shall be replaced

Option 1:



Option 2:





Picture No. 5 Data labels

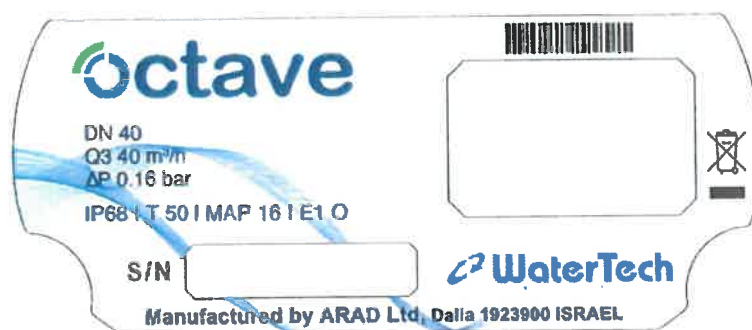

Picture No. 6 Additional marking available for WaterTech

8 Conditions of conformity assessment of measuring instruments produced with type approval

Ultrasonic water meter put onto the market in line with the procedure of conformity assessment according to the Annex No.2 (Module D or F) of the Governmental ordinance should be in compliance with the technical description by the item 3 of this report and at test should be in compliance with the requirements determined in OIML R 49-1:2013 and EN ISO 4064-1:2017. Metrological test is performed by testing equipment which should be in compliance with the requirements determined in EN 14154-3:2005+A2 and EN ISO 4064-2:2017 and water at temperature 20 °C ± 10 °C in following points of flowrate:

- a) Minimum flowrate $Q_1 \leq Q \leq 1,1Q_1$
- b) Transitional flowrate $Q_2 \leq Q \leq 1,1Q_2$
- c) Permanent flowrate $0,9Q_3 \leq Q \leq Q_3$

A metrological test may only be performed by a producer, or a notified body respectively in line with the conformity assessment procedure according to the Annex No.2 (Module D or F) of the Governmental ordinance respectively.

9 Measures asked for providing measuring instrument integrity

9.1 Identification

Ultrasonic water meter should be in compliance with the description provided on item 3 of this Annex and should be in compliance with the marking specified the item 7 of this Annex. The number given to the EU-type examination certificate is put at each piece of the measuring instrument.

Emplacement of the conformity mark is followed by § 15 of the Governmental ordinance.

9.2 Sealing of the measuring instrument

Ultrasonic water meter shall be sealed before the conformity assessment according to the Annex No.2 (Module D or F) of the Governmental ordinance sealed by following sealing marks:

The Octave meter has five plastic seals:

- two seals are placed on the Sensor Cover Plates screws, one on each plate. On plastic bodies the sensor covers are seals,
- two seals are implemented on the meter Face Plate,
- one seal covers the screw of the Comm. output cover.



Picture No.7 Emplacement of the seals for security measures

9.2.1 Software Security

The Octave Water Meter incorporates “Built for Purpose” software (Type P). Access to CPU, for software revisions, can only be done via a specific J-Tag connector on the PCB. In order to reach the PCB the meter must be disassembled:

- breaking two (2) seals,
- breaching the vacuumed Electronics Compartment.

The legal parameters are stored on a read-only memory. The legally relevant software is identified by a CRC-16. The user software is not identified by a CRC.

The user software (GUI) does not contain or store any legally relevant data. Once connected – it reflects the setup stored in the meter to the user software.

It allows the user to set the meter outputs and functionality, without the ability to change the accuracy or the way the meter is measuring.

The connection between the meter and the user software is either RS232 UART or NFC , in both cases any “set” command is validated by a CRC to ensure it came as expected.

The present software version 4.02 is shown on the data label (Picture No.5 and No. 6).

10 Requirements for installation, especially conditions of usage

10.1 Installation data:

Model		Octave				
Nominal size	[mm]	40 Threaded	50 Threaded	DN50	DN65	DN80
	[inch]	1 ½ Threaded	2 Threaded	2	2,5	3
<i>L</i> - Length without couplings [mm]		300	300	200	200	225
<i>W</i> - Width [mm]		113	113	165	185	200
<i>H</i> - Overall Height [mm]		155	155	194	210	210
<i>h</i> - Height above axis [mm]		35	35	40	90	90
Weight [kg] <i>cast iron body</i>			8	9	11,5	13
Weight [kg] <i>polymer body</i>		1,4	1,45			
Weight [kg] <i>stainless steel body</i>		4	4	6		7

Model		Octave				
Nominal size	[mm]	DN100	DN150	DN200	DN250	DN300
	[inch]	4	6	8	10	12
<i>L</i> - Length without couplings [mm]		300	300	350	449	499
<i>W</i> - Width [mm]		113	285	340	406	489
<i>H</i> - Overall Height [mm]		155	282	332	383	456
<i>h</i> - Height above axis [mm]		35	140	165	203	245
Weight [kg] <i>cast iron body</i>			32	45	68	96
Weight [kg] <i>polymer body</i>		1,4				
Weight [kg] <i>stainless steel body</i>		4	16			

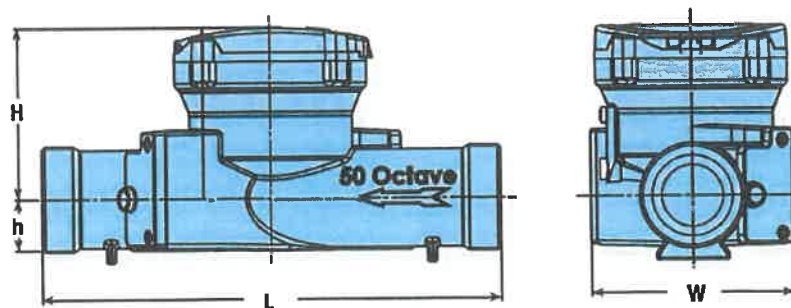

Picture No.8 Installation dimensions - Threaded

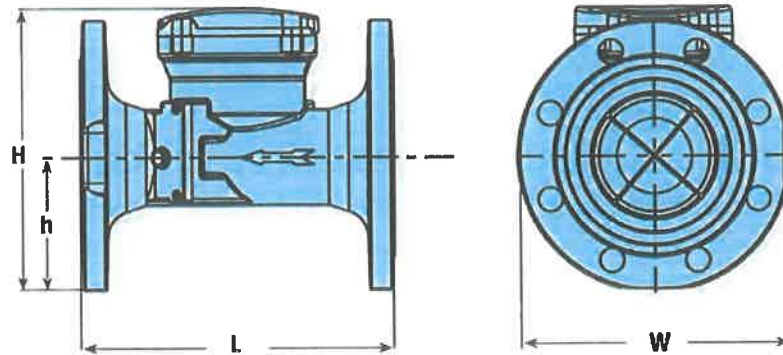

Picture No.9 Installation dimensions - Flanged

10.2 Installation requirements

The Ultrasonic water meter is introduced into the operation by a worker having a certificate for this activity performance. The Ultrasonic water meter is possible to be put into use after a construction in line with this report and in line with a producer instruction by "Instruction of installation and conditions of use of water meters". A measuring instrument should be installed in direction of water flow arrow marked on the meter body.

Assessment done by: Ing. Viliam Mazúr

